

Tolerances unless otherwise specified:
 EN-ISO 2768 - 1C (machined details)
 EN-ISO 13920B (welded constructions)

-Sharp edges broken
 -No thermal wounds
 -Dimensions before surface treatment

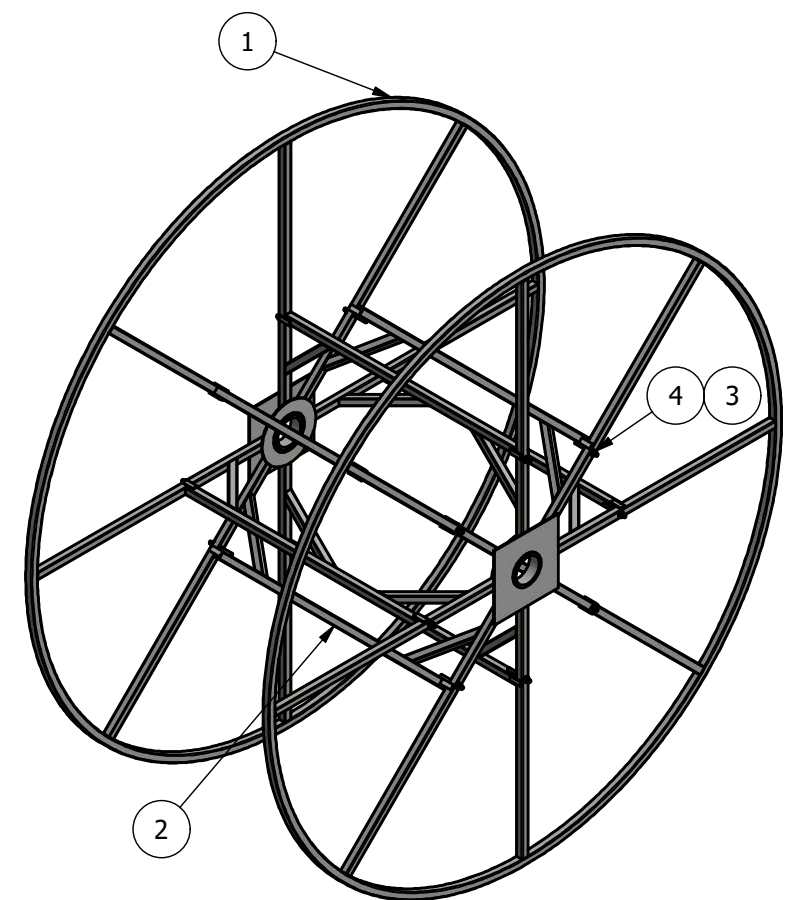
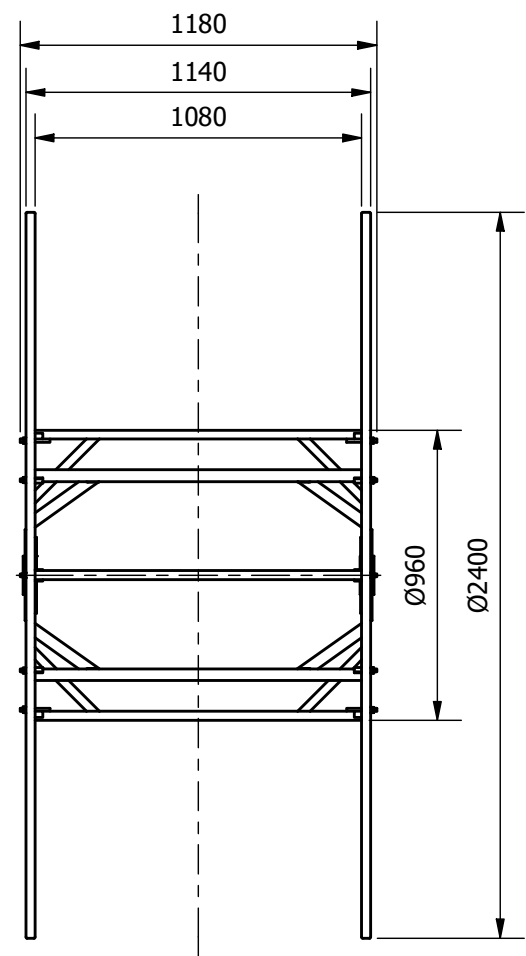
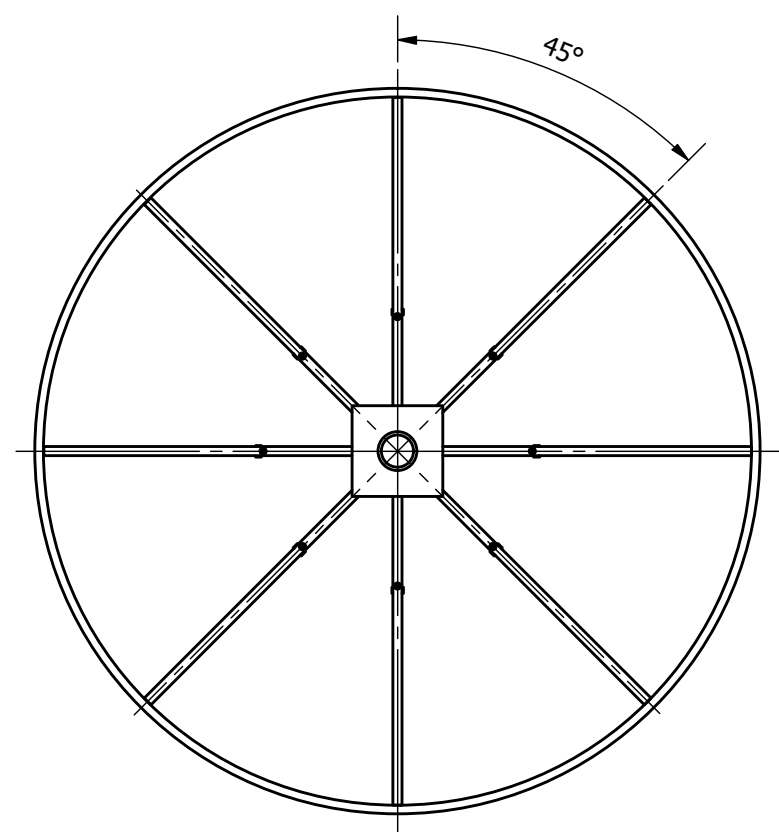

4	16	Nut	934-10	M6M 10		8/FZB	0,0
3	16	Washer	125A-14	RB 10,5x20x2		140HV/FZB	0,0
2	8	Barrel section	337733				4,1
1	2	Flange	337732				44,4
Item	Qty	Description	Part No	Specification	L	Material	Mass

This drawing remains the property of Svensson Group. Unauthorized use is prohibited according to applicable law.



www.svenssongroup.se
info@svenssongroup.se

Title/Description
Reel Ø2400-Ø960-1080

Specification
Design load = 1 TONNES

Customer

Drawing number	337731	Rev.	1				
State	Work in Progress	Drawn by	RB	Checked by		Approved by	
Date	2019-03-18	Our Quotation/Order no.		Scale	1 : 25	Sheet format	A3
Material (only on parts)		Weight	N/A	Sheet/No of sheets	1 / 1		

1	Issued For Construction	2019-03-18	RB
REV	DESCRIPTION	DATE	APPR.
REVISION HISTORY			