

Tolerances unless otherwise specified:
 EN-ISO 2768 - 1C (machined details)
 EN-ISO 13920B (welded constructions)

-Sharp edges broken
 -No thermal wounds
 -Dimensions before surface treatment

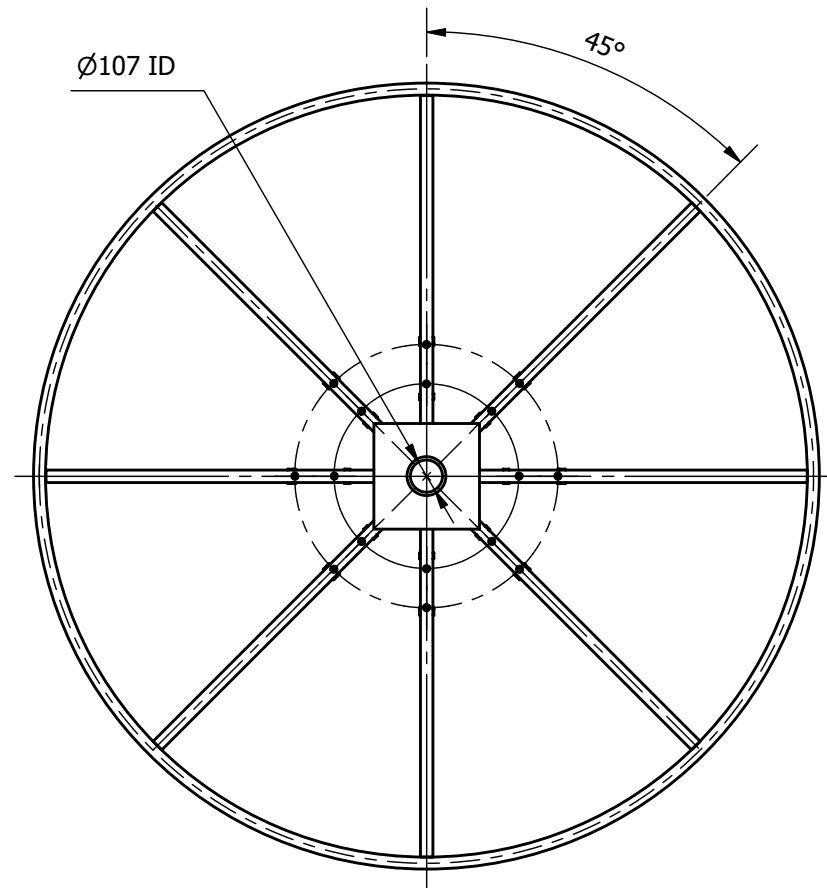

(1 : 25)

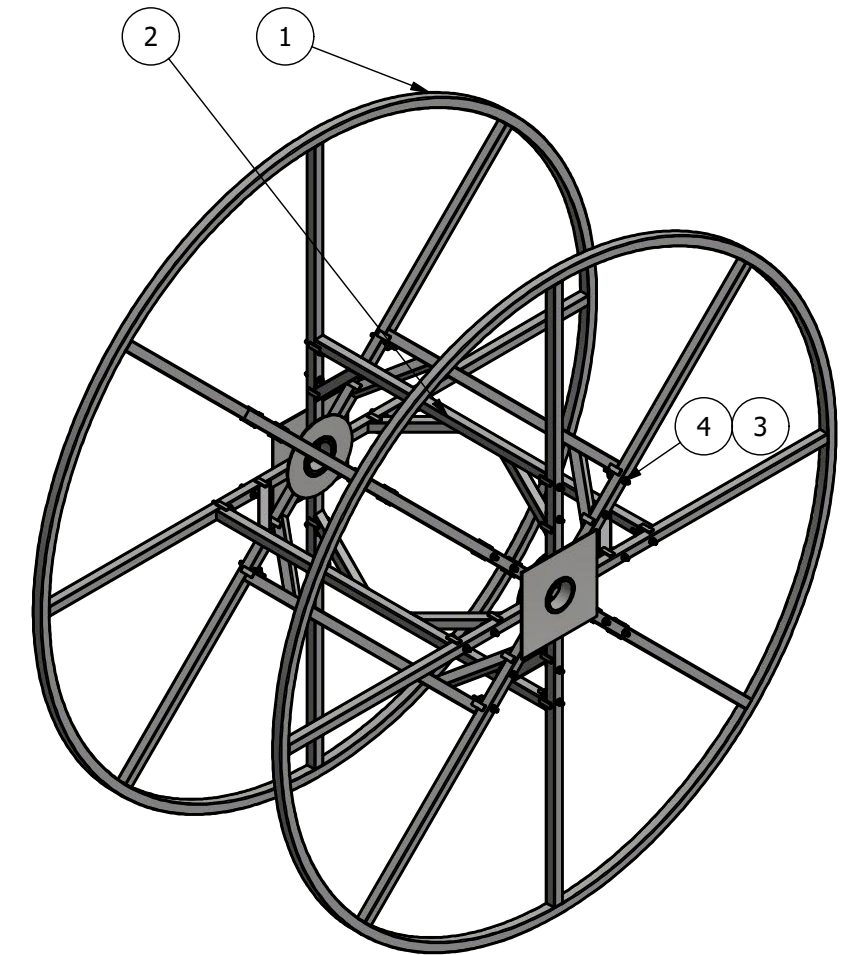
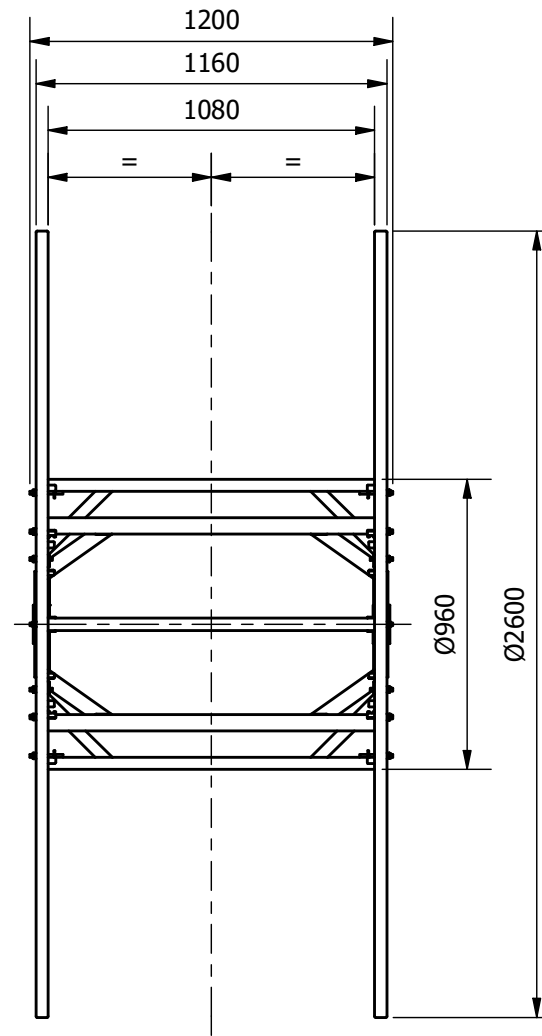

4	32	Nut	934-10	M6M 10		8/FZB	0,0
3	32	Washer	125A-14	RB 10,5x20x2		140HV/FZB	0,0
2	8	Barrel section	338254				5,8
1	2	Flange Ø2600	338259				66,0
Item	Qty	Description	Part No	Specification	L	Material	Mass

This drawing remains the property of Svensson Group. Unauthorized use is prohibited according to applicable law.



Reel Ø2600-Ø960-1080

Design load = 1.25 TONNES

1	Issued For Construction	2021-08-18	RB
REV	DESCRIPTION	DATE	APPR.
REVISION HISTORY			

Drawing number 338253		Rev. 1	
State Work in Progress	Drawn by RB	Checked by	Approved by
Date 2021-08-18	Our Quotation/Order no.	Scale 1 : 25	Sheet format A3
Material (only on parts)	Weight 178,8 kg	Sheet/No of sheets 1 / 1	